

Insulated Multi-Functional Cookers

Electric
Insulated for Safety™
10° Tilting, Leg Mounted
Made in USA

Skittle® Model SK

Standard Features



Model SK10-9
(with optional food pans)

- ◆ 316L stainless food contact zone with:
 - ◇ 316 stainless 1.5" compression draw-off
- ◆ 304 stainless seam welded pan body with:
 - ◇ 10° tilting pan, 31" working height
 - ◇ Food pan holder under draw-off (except SK5)
 - ◇ Insulated sides and bottom
 - ◇ Tapered access rim
 - ◇ 240V, three phase (3φ) standard
- ◆ Adjustable thermostat (175°F to 400°F)
- ◆ High limit safety thermostat
- ◆ Patented 304 stainless seam welded Capsule Lid with:
 - ◇ Variable position, actuator-assisted opening
 - ◇ Insulated sides & top
 - ◇ Adjustable steam vent
 - ◇ 304 stainless safety handle
 - ◇ "L" Lid condensate containment
- ◆ Cassette rack(s) for 12 x 20 food pans
- ◆ 304 stainless, seam welded component enclosure
- ◆ 304 stainless, seam welded tubular frame construction
- ◆ Single ball valve with 48" s/s flexible spray hose assembly
- ◆ Adjustable flanged feet

Legion equipment is built to comply with applicable standards for manufacturers. Approval agencies may include ASME, NSF, UL, ETL, AGA, CSA, CGA and others. Legion reserves the right of design improvement or modification as warranted.

Models and Capacities

Optional Features and Accessories

See price list for supplemental information regarding options

Model	2.5" Insert Pans	Cooking Baskets	Griddle Area (in. ²)	Kettle (Gals.)	Frying Oil (lbs.)	Oven Volume (ft. ³)
SK5-5	5	4	351	7.6	35	3.9
SK5-7	5	4	351	10.6	35	4.3
SK5-9	5	4	351	13.7	35	4.7
SK10-5	10	8	703	15.2	70	7.7
SK10-7	10	8	703	21.3	70	8.5
SK10-9	10	8	703	27.4	70	9.4
SK10-11	10	8	703	33.5	70	10.2
SK15-5	15	12	1029	22.3	105	11.3
SK15-7	15	12	1029	31.2	105	12.5
SK15-9	15	12	1029	40.1	105	13.7
SK15-11	15	12	1029	49.0	105	14.9

Faucet Options:

- _Single ball valve mounted to frame with 48" vinyl flexible spray hose assembly
 - _48" flexible spray hose assembly (vinyl or stainless) for use with dual or single fill faucet
 - _Automatic water filling meter
- (Call for information regarding additional faucet options)*

Prison/Security Options:

- _Fasteners (screws & nuts)
- _Nut driver tool
- _Draw-off nut driver tool
- _Screw driver tool
- _Lockable control cover
- _Draw-off protection

Other Options:

- _Electric timer with buzzer
- _Knockdown capability for 26" x 66" opening (*shipped assembled*)

Accessories:

- _Perforated cooking/steaming basket (11" x 20½" x 5")
- _Perforated or solid 12 x 20 food pans, 2½, 4 or 6 inch deep
- _Draw-off drain spout
- _Draw-off strainer
- _Draw-off drain hose
- _#10 Can holder for draw-off
- _Flat bottom scoop
- _Fry scoop
- _Skittle care kit

Select draw-off valve: 1.5" 2" 3"

With: compression ball type fitting

See price list for other draw-off options.

Select Voltage: 208V 240V 380V 415V 440V 480V

Select Phase: 1φ 3φ

Revision 1102

**Legion Industries, Inc., Post Office Box F, Dallas, PA 18612, (800) 833-9803, (570) 675-1595,
Fax: (570) 675-7551, www.legionindustries.com, sales@legionindustries.com**

Skittle® Model SK

Electric
Insulated for Safety™
10° Tilting, Leg Mounted
Made in USA

Insulated Multi- Functional Cookers

DRAWING REPRESENTS MODEL SK10-7 WITH 1 1/2 DRAW-OFF

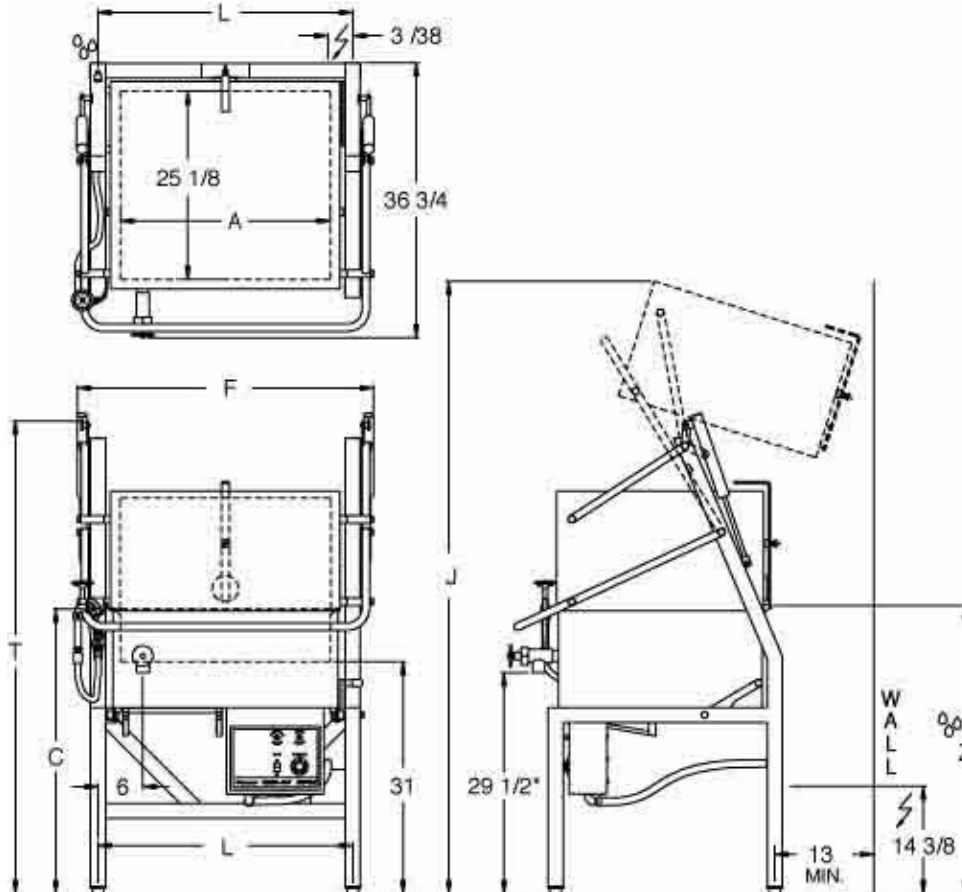

SKITTLE® DIMENSIONS

Model*	A	F	L	Model*	A	F	L	Model*	A	F	L	Depth	C	J	T	Z
SK5-5	14.0	25.5	20.0	SK10-5	28.0	39.5	34.0	SK15-5	41.0	52.5	47.0	5	36.0	79.8	61.1	36.3
SK5-7	14.0	25.5	20.0	SK10-7	28.0	39.5	34.0	SK15-7	41.0	52.5	47.0	7	38.0	81.8	63.1	38.3
SK5-9	14.0	25.5	20.0	SK10-9	28.0	39.5	34.0	SK15-9	41.0	52.5	47.0	9	40.0	83.8	65.1	40.3
N/A			SK10-11**	28.0	39.5	34.0	SK15-11**	41.0	52.5	47.0	11	42.0	85.8	67.1	42.3	

*Dimensions on these drawings are applicable only when using a 1.5" diameter draw-off valve. If a 2" or 3" diameter draw-off valve is required, contact Legion for applicable dimensions.

**Note: Vertical dimensions of 11" deep pan may be reduced by 2" to match 9" deep pan

SKITTLE® ELECTRICAL SPECIFICATIONS (Amperes per Leg)

Model*	kW	208 Volt		240 Volt		380 Volt		415 Volt		440 Volt		480 Volt	
		1φ	3φ	1φ	3φ	1φ	3φ	1φ	3φ	1φ	3φ	1φ	3φ
SK5-()	7.2	34.6	20.0	30.0	17.3	18.9	10.9	17.3	10.0	16.4	9.4	15.0	8.7
	9.6*	46.2	26.6	40.0	23.1	25.3	14.6	23.1	13.4	21.8	12.6	20.0	11.5
SK10-()	14.4	69.2	40.0	60.0	34.6	37.9	21.9	34.7	20.0	32.7	18.9	30.0	17.3
	19.2*	92.3	53.3	80.0	46.2	50.5	29.2	46.3	26.7	43.6	25.2	40.0	23.1
SK15-()	21.0	101.0	58.3	87.5	50.5	55.3	31.9	50.6	29.2	47.7	27.6	43.8	25.3
	27.6*	132.7	76.6	115.0	66.4	72.6	41.9	66.5	38.4	62.7	36.2	57.5	33.2

*Note: Add prefix H to above models to designate High Output Models, i.e. SK10-7 becomes HSK10-7

U.S. Patent Nos. 5,553,531, 5,964,145, & Des. 371,715

Revision 1102

**Legion Industries, Inc., Post Office Box F, Dallas, PA 18612, (800) 833-9803, (570) 675-1595,
Fax: (570) 675-7551, www.legionindustries.com, sales@legionindustries.com**