

COMBI-PAN® TILTING SKILLETS

**DIRECT STEAM
Insulated for Safety™
10° TILTING PAN
LEG MOUNTED, MADE IN USA**

MODEL DCS

STANDARD FEATURES

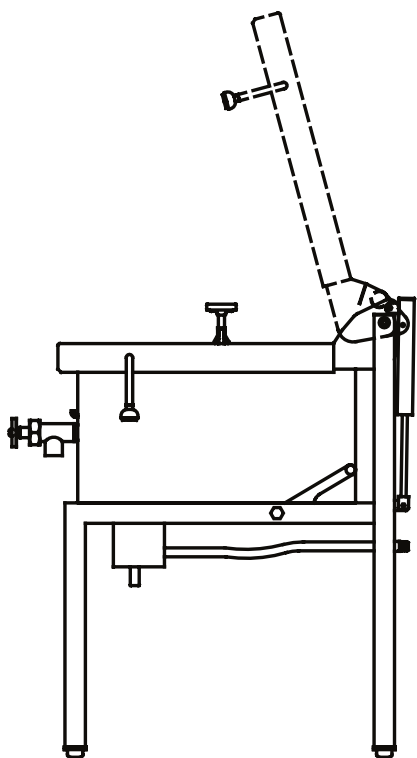

Model DCS28-9

- ◆ 316L stainless food contact zone with:
 - ◇ 316 stainless 1 ½" compression draw-off
- ◆ 304 stainless seam welded pan body with:
 - ◇ 10° tilting pan, 31" working height
 - ◇ Insulated sides and bottom
 - ◇ Rear drip collector on pan body
 - ◇ Tapered access rim
 - ◇ Steam Control (1" ball valve)
- ◆ Maximum operating pressure 125 psi (353° F)
- ◆ Safety valve, 125 psi
- ◆ 304 stainless patented safety lid, seam welded with:
 - ◇ Actuator-assisted counterbalance
 - ◇ Full width condensate drip shield
 - ◇ Full width rear steam vent
 - ◇ Dual side-mounted safety handles
- ◆ 304 stainless, seam welded component enclosure
- ◆ 304 stainless, seam welded tubular frame construction
- ◆ Adjustable feet (*flanged front, bullet rear*)
- ◆ Approved for use as a fryer

Legion equipment is built to comply with applicable standards for manufacturers. Approval agencies may include ASME, NSF, UL, ETL, AGA, CSA, CGA, and others. Legion reserves the right of design improvement or modification as warranted. US Patent No. 5,865,101.

MODELS AND CAPACITIES						OPTIONAL FEATURES AND ACCESSORIES	
						See price list for supplemental information regarding options	
						Select draw-off: <input type="radio"/> 1½" <input type="radio"/> 2" <input type="radio"/> 3" With: <input type="radio"/> Compression <input type="radio"/> Ball type fitting	
Model	2.5" Pans or Cooking Baskets	Griddle Area	Kettle (Gals.)	Frying Oil (lbs.)	Oven Volume (ft. ³)	<input type="radio"/> Single ball valve mounted to frame with 48" s/s flexible spray hose assembly <input type="radio"/> Single ball valve mounted to frame with 48" vinyl flexible spray hose assembly <input type="radio"/> Dual fill faucet & bracket with 48" s/s flexible spray hose assembly <input type="radio"/> Dual fill faucet & bracket with 48" vinyl flexible spray hose assembly <input type="radio"/> Automatic water filling meter <i>(Call for information regarding additional faucet options)</i> <input type="radio"/> Knockdown capability for 26"x66" opening (<i>shipped assembled</i>) <input type="radio"/> Casters (two each locking /non-locking type) & restraining devices <input type="radio"/> Adjustable flanged feet (<i>rear feet</i>) <input type="radio"/> Draw-off drain spout <input type="radio"/> Draw-off strainer <input type="radio"/> Draw-off drain hose	<input type="radio"/> #10 can holder for draw-off <input type="radio"/> Flat bottom scoop <input type="radio"/> Fry scoop <input type="radio"/> Perforated or solid 12x20 food pans 2½, 4, or 6" deep <input type="radio"/> Perforated cooking/steaming basket (11 x 20½ x 5) <input type="radio"/> Combi-Pan® Skillet care kit <input type="radio"/> PVC drain tube for condensate Prison/Security Options: <input type="radio"/> Fasteners (<i>screws & nuts</i>) <input type="radio"/> Nut driver tool <input type="radio"/> Screw driver tool <input type="radio"/> Draw-off nut driver tool <input type="radio"/> Lockable lid <input type="radio"/> Lockable control cover <input type="radio"/> Draw-off protection
DCS28-5	2 Pans Only	703	15.2	70	2.0		
DCS28-7	2	703	21.3	70	2.8		
DCS28-9	2	703	27.4	70	3.7		
DCS28-11	2	703	33.5	70	4.5		
DCS28-14	2	703	42.6	70	5.7		
DCS41-5	3 Pans Only	1029	22.3	105	3.0		
DCS41-7	3	1029	31.2	105	4.2		
DCS41-9	3	1029	40.1	105	5.4		
DCS41-11	3	1029	49.0	105	6.6		
DCS41-14	3	1029	62.4	105	8.4		



LEGION LEGION INDUSTRIES, INC. ♦ P.O. BOX F ♦ DALLAS, PA ♦ 18612
(800) 833-9803 ♦ (570) 675-1595 ♦ Fax: (570) 675-7551 ♦ www.legionindustries.com

**Model
DCS**

**DIRECT STEAM
Insulated for Safety™
10° TILTING PAN
LEG MOUNTED, MADE IN USA**

**COMBI-PAN®
TILTING SKILLETS**

DRAWING REPRESENTS MODEL DCS28-9 WITH STANDARD 1 1/2" DRAW-OFF VALVE AND OPTIONAL SINGLE BALL VALVE SPRAY HOSE ASSEMBLY

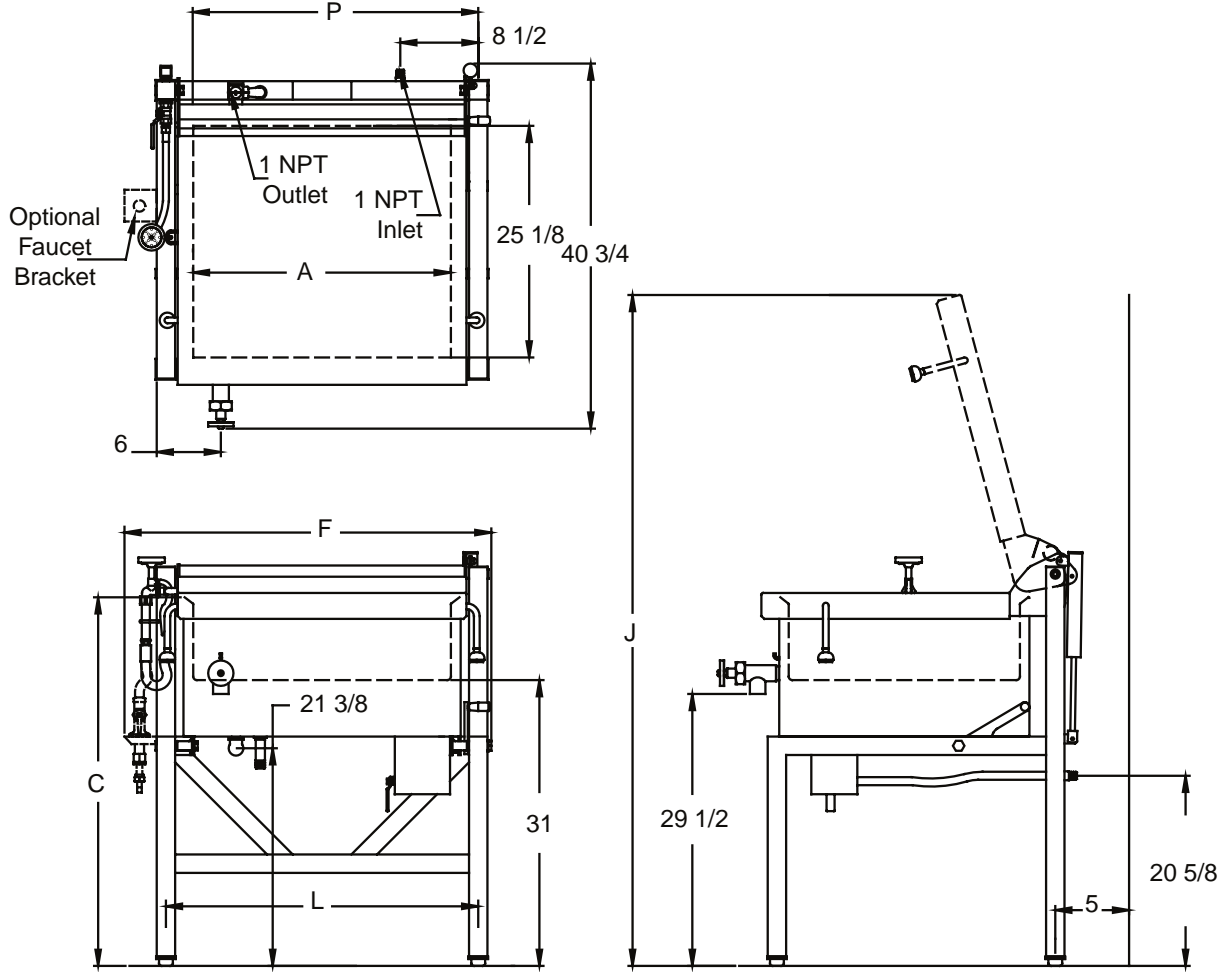

COMBI-PAN SKILLET DIMENSIONS*

Model	Depth	A (PAN ID)	C	F	J	L	P (Drain)	Model	Depth	A (PAN ID)	C	F	J	L	P (Drain)
DCS28-5	5	28.0	36.0	40.0	68.8	34.0	32.4	DCS41-5	5	28.0	36.0	40.0	68.8	34.0	32.4
DCS28-7	7	28.0	38.0	40.0	70.8	34.0	32.4	DCS41-7	7	28.0	38.0	40.0	70.8	34.0	32.4
DCS28-9	9	28.0	40.0	40.0	72.8	34.0	32.4	DCS41-9	9	28.0	40.0	40.0	72.8	34.0	32.4
DCS28-11	11	28.0	42.0	40.0	74.8	34.0	32.4	DCS41-11	11	28.0	42.0	40.0	74.8	34.0	32.4
DCS41-14	14	28.0	45.0	40.0	77.8	34.0	32.4	DCS41-14	14	28.0	45.0	40.0	77.8	34.0	32.4

*Dimensions on these drawings are applicable only when using a 1.5" draw-off valve. If a 2" or 3" diameter draw-off valve is required, contact Legion for applicable dimensions.

Revision 201

